

MOTOR MIT DOPPELTEN DREHMOMENT
(MIT EINGEBAUTEN KONDENSATOR)

MOTEUR A DOUBLE ROTATION
(AVEC CONDENSATEUR INCORPORÉ)

MOTOR CON DOBLE ROTACION
(CON CONDENSADOR INCORPORADO)

MOTORE A DOPPIA ROTAZIONE
(CON CONDENSATORE INCORPORATO)

- ① BLAU / BLEU / AZUL / AZZURRO
- ② BRAUN / MARRON / MARRON / MARRONE
- ③ SCHWARZ / NOIR / NEGRO / NERO
- ④ GRAU / GRIS / GRIS / GRIGIO

DREHMOMENT RECHTS (UHRZEIGER-SINN)
ROTATION DE GAUCHE A DROITE
ROTACION HORARIA
ROTAZIONE ORARIA

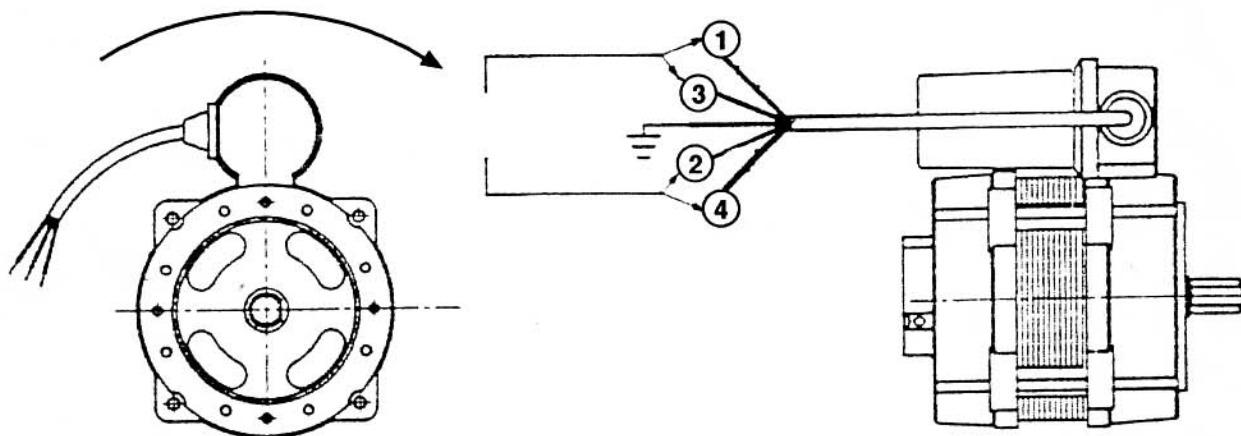

DREHMOMENT LINKS (UHRZEIGER-SINN)
ROTATION DE DROITE A GAUCHE
ROTACION ANTIHORARIA
ROTAZIONE ANTIORARIA

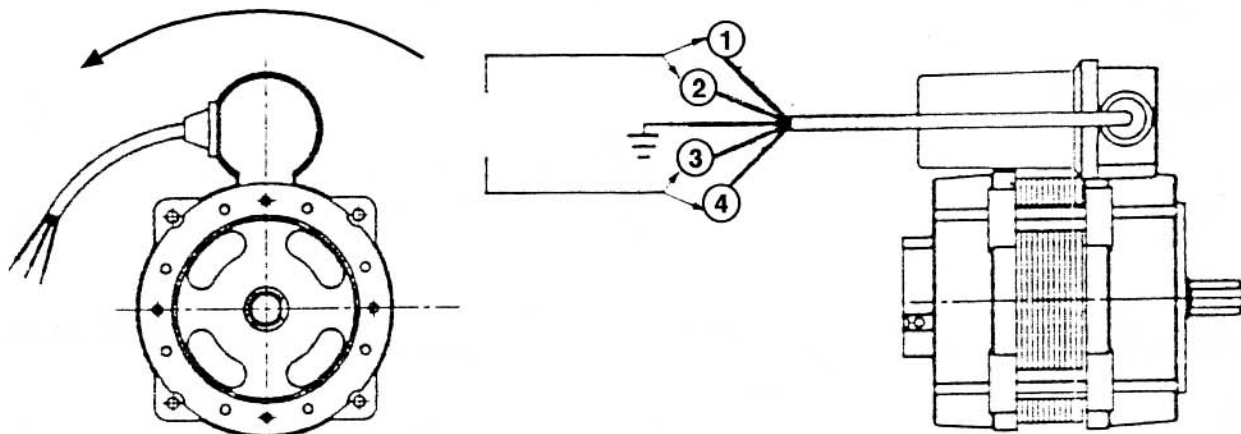

Schema motore R.045.90

