



## SOLAR CONTROL

T.127.04



The **solar control** contains in its small size a great technology.

This equipment allows to keep under control the precise temperature resulting from the solar panels and distribute it to various boiler of accumulation and to the integration of heating. This viewing via the display in a sequential way the temperatures of both of the panels that boilers.

Through the sensors of endowment it detects the water temperature in boiler of accumulation and compares it with the temperature of the fluid of the solar panels. When the temperature of the panels is greater than that of the water of the boiler, the control unit starts the pump that allows the exchange of heat between the panel and boiler.

To assure a perfect exchange of temperatures of the equipment is endowed with a differential of temperature "delta **T**" varying from 3 ° C to 15 ° C adjustable via buttons on front panel of the unit. With the **Solar Control** it is possible the integration to both to the sanitary water that for the plant of traditional heating.

### Installation and user guide

Firmware

Version 1.0

### CONFORMITY

EMC EN50270

#### Important Note

Before connecting the unit careful reading of instruction booklet is recommended, and it is kept in a safe place for future reference.

Furthermore, the correct electrical connections according to the enclosed drawings, complying with instructions and regulations in force, is recommended.

## Main Features

### Configuration of 4 different solar installations

- 1° Installation Panel Boiler
- 2° installation Panel Boiler and Boiler Accumulation with automatic temperature control.
- 3° System Integration to the heating system with automatic control
- 4° System Integration to the system of the swimming pool with automatic control

Priority to the domestic water.  
Thermostat setting of sanitary water of the first boiler.  
Automatic activation of the system integration of sanitary water.  
Display LCD  
4 separate inputs for NTC probes.  
Individual correction Offset probes ( $\Delta T$ ) from 3 ° to 15 ° C  
Graphical display of configured machines.  
Diagnostics on the front panel status of the probes and messages of failure or lack of connection.  
Control panel on the state of the inputs / outputs (turning on or off of utilities )  
Reading range temperature -20 ° C .. + 120 ° C  
Display of the temperatures of the solar panels.  
Display of the temperatures of the boiler.  
Display of the temperature of the heating system.  
Acoustic and visual alarm in case of failure .  
Activation of auxiliary relay in case of alarm.  
Self-diagnosis of the installation.  
Manual activation of the recirculation pump.  
Manual activation of the integration.

## Technical Features

Power supply ..... 230V~  $\pm 10\%$  50Hz  
Power demand ..... 2 VA  
Relay Contact Range..... 10A 250V. resistive 5A 30V. inductive  
**Free of voltage contacts**

Type of sensors ..... NTC 47k  
Functioning temperature sensors..... -20°C .. 120° C  
Campo di lettura temperature: ..... -20°C .. 120° C  
Accuracy: .....  $\pm 1^\circ$  C  
Resolution : ..... 1 °C

Acoustics signal: ..... failure probes

Max. distance between probes and unit ..... 150 m  
Cable diameter for connecting probes..... 1 mm<sup>2</sup>

Mounting: .....panel mounting  
Degree of protection ..... IP20 in air  
Functioning temperature ..... 0°C to 50°C  
Storage temperature ..... -10°C to +60°C  
Humidity limits ..... 90% RH non-condensing  
Omega-type size DIN EN 50092 9 modules ..... 158\*90\*58  
Electromagnetic Compatibility "CE" ..... Reference norms  
Warranty ..... Three years

## Check the Package Contents

Verify that the package contains the items listed below.

N° 1 Control unit SOLAR CONTROL SC200  
N° 4 sensors control temperature in thermoplastic watertight enclosure, Immersion version with IP55 protection degree.



## Accessories on demand

Temperature control probes in the version with cockpit and cockpit's cover watertight enclosure made of chromed brass protection degree IP67.



## Precautions

In order to achieve long and satisfactory use of your control unit **Solar Control**, use and store it by respecting the following precautions.

**Do not allow it to become wet.**

The control unit can be seriously damaged as it is not waterproof either when immersed in water or exposed to high levels of humidity.

**Do not drop it.**

Heavy knocks on hard surfaces and strong vibrations can damage the appliance.

**Avoid abrupt temperature fluctuations.**

Sudden temperature variations can cause condensation and the control unit could may not work well.

In addition the temperature of + 45 ° cc / in the display goes black in this case to cool to make it visible.

**Cleaning**

Never clean the device with chemical products. If necessary, wash with a moist cloth.

## Before calling a technician, check...

**If the device does not turn on:** Check that all the 230V cables are firmly connected the terminal block's poles 1 and 2. Check if the mains power supply is present

**The control unit is faulty repeatedly:** verify that the probes supplied are connected correctly, and in their location, that there are interuzioni of electrical cables and that the ohmic values are correct

**The control unit works well but cannot drive the appliances:** Check that all the wiring is correct. Please remind that all relays are free of voltage. Check that the resistive values are right. Please see table on the side.

**The display is dimmed and you can not read it:** cool bringing it back under 45 ° C.

### PROBES

Conversion from temperature to ohmic value of the probes

| Temp. | Resistive values | Temp. | Resistive values |
|-------|------------------|-------|------------------|
| 0°C   | 155.820          | 10°C  | 94.523           |
| 30°C  | 37.704           | 40°C  | 24.695           |
| 50°C  | 16.533           | 60°C  | 11.296           |
| 70°C  | 7.865            | 80°C  | 5.573            |
| 95°C  | 3.427            | 100°C | 2.936            |

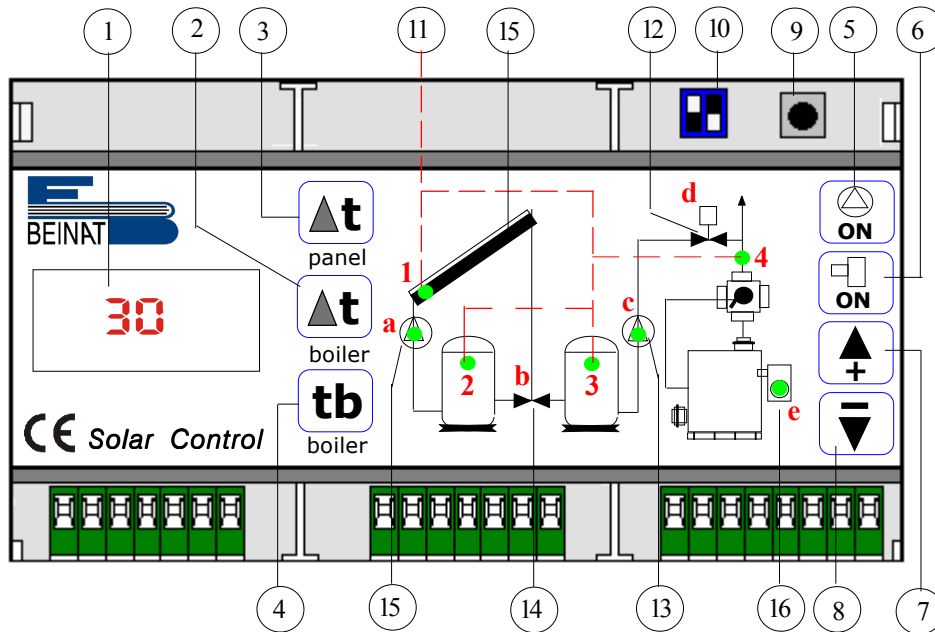

**1) Display.** Used to display all events that occur for programming by the user to read the temperatures detected by the probes.

**2) Button DELTA T boiler or pool .** Is used to program the difference of the temperature between the boiler accumulation and BOILER (set to 5 ° C).

To select the temperature required Press this button, then followed with the buttons " + e - " select the difference of required temperature, wait for 1 second.

**3) Button DELTA T panel.** Is used to program the temperature difference between boiler and PANEL, (set to 5 ° C).

To select the temperature required Press this button, then followed with the buttons " + e - " select the difference of required temperature, wait for 1 second.

**4) Button Temperature Boiler.** Used to set the required temperature of the water in the boiler 1.

To select the temperature required Press this button, then followed with the buttons " + e - " select the difference of required temperature, wait for 1 second.

**5) Button Force Arming of the pump (a), between the boiler and the panel..**

It is used to forced insert the circulation pump between the panel and boiler.

Each press will appear on the display the written: **ON - Aut** and as a consequence you will see turning on the led of the pump ( a )

**6) Button Integration.** Used to arm or disarm the device integration, boiler, electric heater or other sources integrative.

Each press will appear on the display the written: **ON - OFF - Aut** and as a consequence you will see turning on the led of ( e ) of the burner (the LED is indicative of the burner could also be another source of integration).

**7) Button Increase.** It serves to push up the value of setting temperature.

**8) Decrease Button.** It is used to bring down the temperature setting value.

**9) RESET button .** Pressing this button returns the unit to the factory default values.

**10) Group of switches of SERVICE**

**Inserting the switch N° 1 in ON** you select the option to connect the boiler to accumulation, vice versa OFF is eliminated.

**Inserting the switch N° 2 in ON** you select the option of connecting to the heating system integration, vice versa OFF is eliminated.

- 11) Led Probes 1 - 2 - 3 - 4.** These LEDs indicate the position of the probes. Cyclically turn on with colore GREEN and at each step indicates on the display the temperature they reveal. If to the passage turns on RED, indicates that the probe is damaged or that is disconnected, At the same time they switch the relay fault and the buzzer will emit a sound cyclically at intervals of 5 minutes.
- 12) Valve Opening integration (d) heating or pool.**  
This valve opens when the temperature of Boiler accumulation is warmer than heating system.
- N.B.**The circulation pump ( c ) between the boiler and the heating system you enable with the valve( d ).
- 13) Forced circulation pump between the boiler accumulation heating systems ( c )**  
**N.B.** The valve ( d ) between the boiler and the heating system you enable together with the circulation pump ( c )
- 14) Valve opening to the Boiler Accumulation ( b ).**  
This valve opens when the temperature of the boiler of first collecting has reached the temperatra set by the built-in thermostat.
- 15) Circulation pump between the solar panel and the boiler sanitary. ( a )** This pump starts to move when the tempearture of the solar panel is higher than that of the boiler sanitary.
- 16) Integration ( e ).**This LED indicates that the plant INTEGRATION of any gender it is in operation. The LED indicates the functioning of a burner. In place of the burner can be connected to an electrical resistance, the introduction of hot water from other sources via a solenoid valve or any other kind.

## Dimensions

Omega-type size DIN EN 50092 **9 modules**

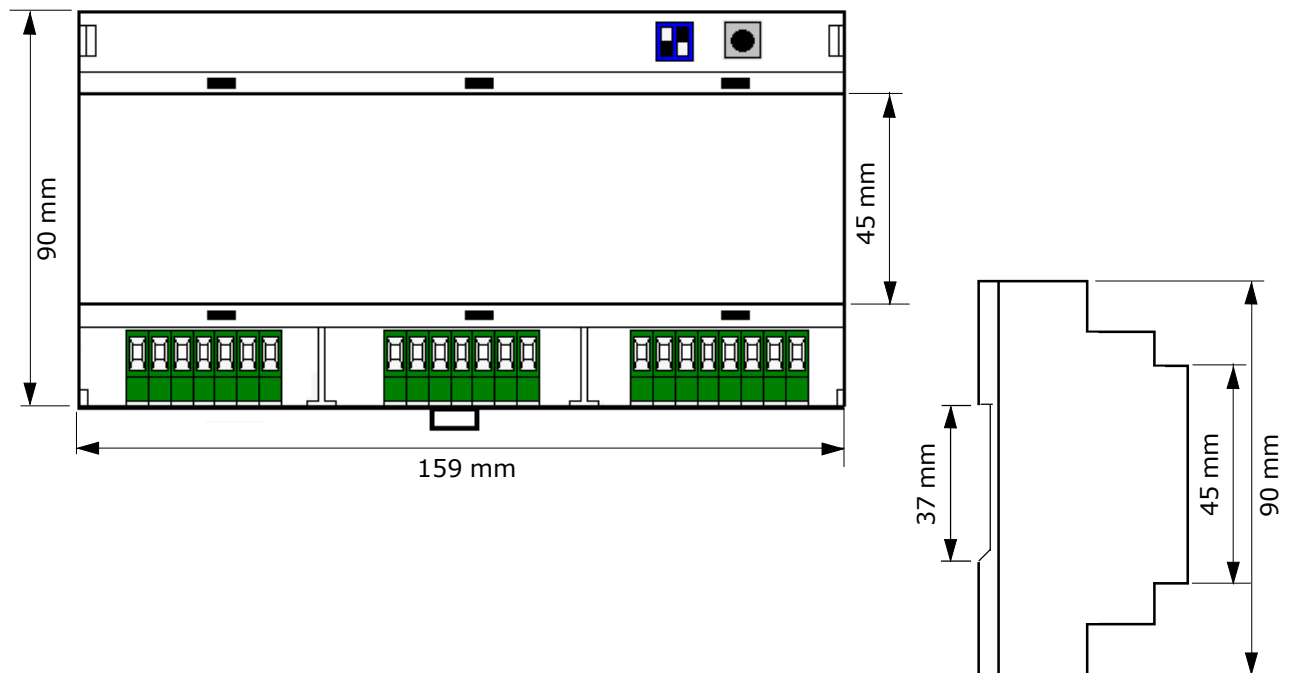

## Temperature settings

### TEMPERATURE SET FACTORY

#### DELTA temperature

Delta between panels and Boiler 5 ° C

Delta between Boiler Accumulation and heating system 5 ° C

#### Temperature Water Sanitary

Adjustable thermostat set to 40 ° C

#### Temperature integration

The temperature of integration is set by the thermostat of sanitary water.

If the temperature set by the thermostat does not reach the temperature default the alternative source is put into operation.

#### Temperature settings

#### DELTA temperature

Delta between panels and Boiler from 3 ° to 15 ° C CM

Delta between Boiler Accumulation and installation of heating or pool from 3 ° C to 15 ° C

#### Temperature water sanitary

Adjustable thermostat from 25 ° C to 90 ° C

## Various types of system

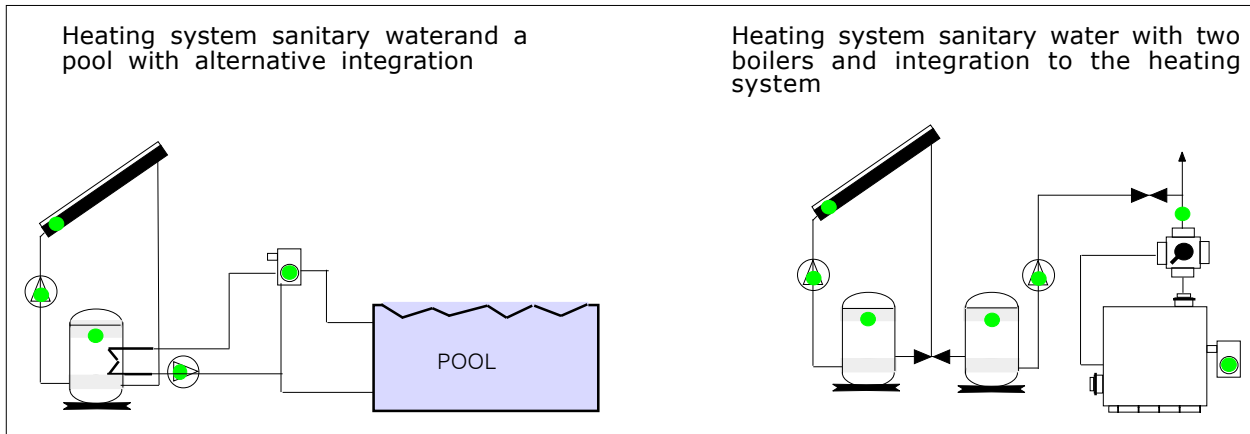
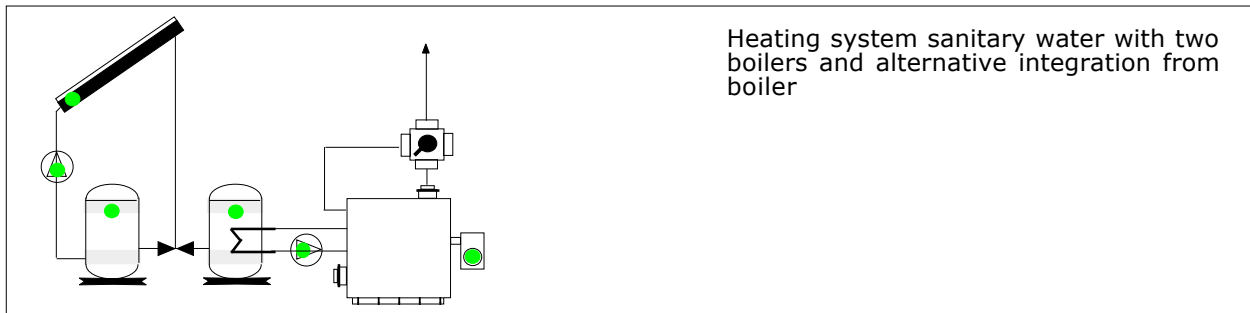
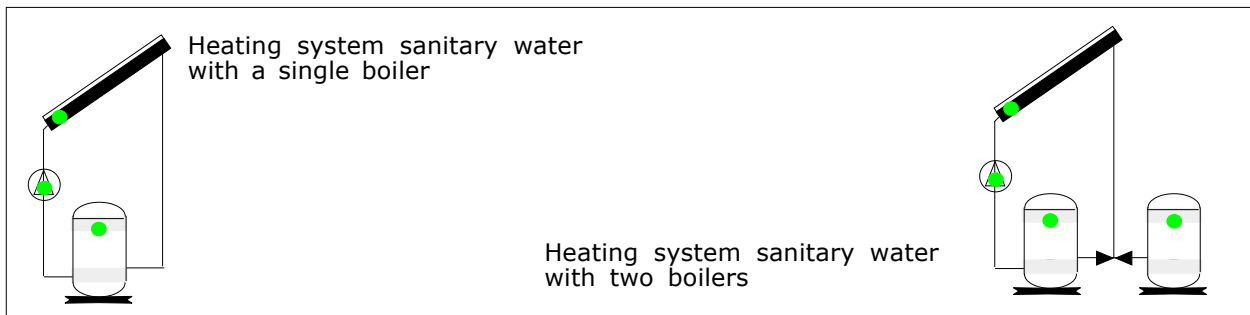

## Electrical Connections

### WARNING.

Before connecting to the mains power, ensure the voltage is correct. Carefully follow the instructions and the connections according to Regulations in force, keeping in mind that the signal cables should be laid separate from the power cables.

Electrical connection of the 1 terminal block (left)

Relays schematized are free of voltage with a range of 10 A resistive.

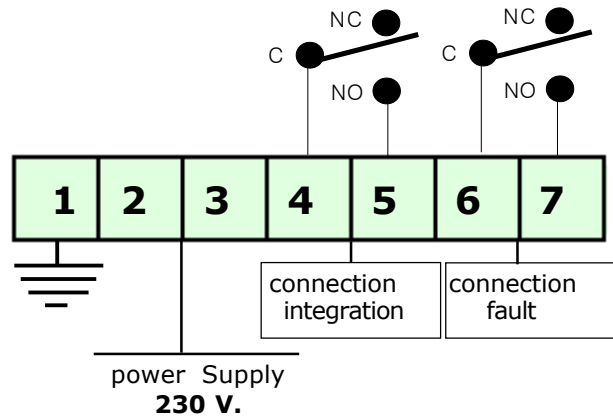

Electrical connection of the 2nd terminal (central)

Relays schematized are free of voltage with a range of 10 A resistive.

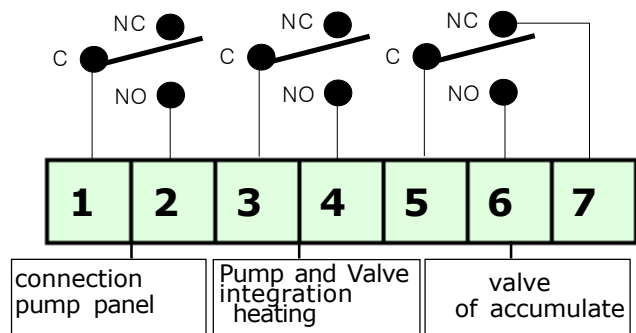

Electrical connection of the 3rd block (right)

The immersion probes can be inverted with one another both in location and polarity. Distance max 150 m with a minimum diameter of 1 mm<sup>2</sup>

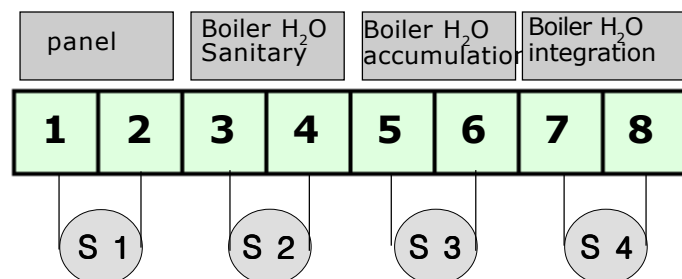

**DISPOSAL OF OLD ELECTRICAL & ELECTRONIC EQUIPMENT.**

This symbol on the product or its packaging indicates that this product shall not be treated as household waste. Instead, it shall be handed over to the applicable collection point for the recycling of electrical and electronic equipment, such as for example:

- sales points, in case you buy a new and similar product
- local collection points (waste collection center, local recycling center, etc...).

By ensuring this product is disposed of correctly, you will help prevent potential negative consequence for the environment and human health, which could otherwise be caused by inappropriate waste handling of this product. The recycling of materials will help to conserve natural resources. For more detailed information about recycling of this product, please contact your local city office, your household waste disposal service or the shop where you purchased the product.

**Attention:** in some countries of the European Union, the product is not included in the field of application of the National Law that applies the European Directive 2002/96/EC and therefore these countries have no obligation to carry out a separate collection at the "end of life" of the product.



Solar Control **T.127.04**

Purchase date

Serial Number

Stamp and signature of the dealee